

COSplay: Contrast Optimized Stimulation Player

Florian Aymanns¹, Markus Rudin², and Horea-Ioan Ioanas²

¹ Department of Information Technology and Electrical Engineering, ETH Zurich ² Institute for Biomedical Engineering, ETH and University of Zurich

DOI: [10.21105/joss.01171](https://doi.org/10.21105/joss.01171)

Software

- [Review](#) ↗
- [Repository](#) ↗
- [Archive](#) ↗

Submitted: 21 October 2018

Published: 16 July 2019

License

Authors of papers retain copyright and release the work under a Creative Commons Attribution 4.0 International License ([CC-BY](https://creativecommons.org/licenses/by/4.0/)).

Summary

In many research areas, the functioning of complex systems is probed by measuring stimulus-evoked responses. Commonly, stimulus train delivery is coordinated by in-house and/or proprietary solutions, which are often ill-documented, expensive, poorly reproducible, high-maintenance, and unsustainable. Here we present COSplay, a fully Free and Open Source (FOSS) and hackable framework consisting of a Micro/Python package and a simple compatible circuit schema, which can be used to build and operate a stimulus train delivery device with up to microsecond accuracy. This project includes a complete, step-by-step video tutorial to demonstrate the assembly of the COSplayer (Aymanns, Rudin, & Ioanas, 2018), a free and open source hardware device which serves as the reference implementation for the technology.

The software and circuit supports highly diverse types of stimulus output, accommodating most experimental scenarios, including:

- amplitude modulation (up to 4.2V)
- event-related designs
- block designs
- tonic stimulation
- multiple stimulation channels
- short-circuit output

The package was extensively tested for viability in a functional magnetic resonance imaging (fMRI) setting, and is used in ongoing investigations using optogenetic and electrical

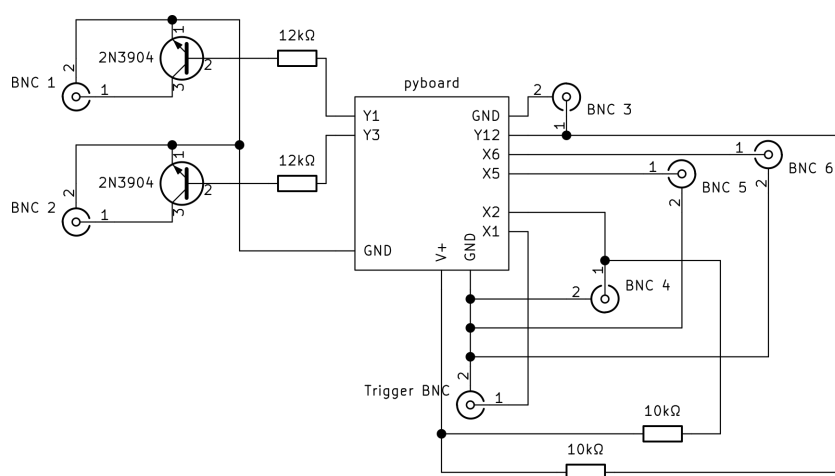

Figure 1: Circuit schema.

stimulation (Ioanas, Saab, & Rudin, 2017). The flexible stimulus train specification is BIDS-conformant (Gorgolewski et al., 2016), and can automatically be parsed for analysis by modern neuroimaging software, including SAMRI (Ioanas, Marks, Schmidt, Aymanns, & Rudin, 2017).

Additionally, the software seamlessly interfaces with the Bruker ParaVision (TM) directory structure, and is able to reposit stimulus summaries in corresponding data paths. This makes COSplay excellently suited for automating the workflow and increasing the reproducibility of small animal MRI studies - while not compromising its potential for other scenarios.

References

- Aymanns, F., Rudin, M., & Ioanas, H.-I. (2018). A Guide to Assembling the COSplayer: an Open Source Device for Microsecond-Range Stimulus Delivery with broad Application in Biomedical Engineering and fMRI. doi:[10.6084/m9.figshare.7227626.v1](https://doi.org/10.6084/m9.figshare.7227626.v1)
- Gorgolewski, K. J., Auer, T., Calhoun, V. D., Craddock, R. C., Das, S., Duff, E. P., Flandin, G., et al. (2016). The brain imaging data structure: A standard for organizing and describing outputs of neuroimaging experiments. *Nature Scientific Data*. doi:[10.1038/sdata.2016.44](https://doi.org/10.1038/sdata.2016.44)
- Ioanas, H.-I., Marks, M., Schmidt, D., Aymanns, F., & Rudin, M. (2017, November). SAMRI - small animal magnetic resonance imaging. doi:[10.5281/zenodo.1044033](https://doi.org/10.5281/zenodo.1044033)
- Ioanas, H.-I., Saab, B. J., & Rudin, M. (2017, April). Longitudinal opto-pharmaco-fMRI of selective serotonin reuptake inhibition. doi:[10.5281/zenodo.573368](https://doi.org/10.5281/zenodo.573368)